



CAW

Ceiling-mounted fan heaters for hot water

CAW

Ceiling-mounted fan heaters for hot water

CAW ceiling-mounted fans are used for heating entrances, warehouses, industrial premises, workshops, sports halls, garages and shops. Due to its low overall height the CAW can be built into the ceiling. The fans are designed for 230V~ power supply, which makes the installation very simple. The fans have a low sound level and offer reliable operation.

- Three sizes and two models
- Available with built-in control equipment for sensor control or for external 0...10V:s control signal
- The hinged front panel makes the coil and fan easily accessible for inspection and cleaning
- Suspended from the ceiling – leaves the wall surface clear
- Low overall height – can be built into the ceiling
- Simple 230V AC installation
- Two fan speeds as standard

Design

The casing is made of galvanized sheet steel painted white. The coil has copper tubes and aluminium fins. The ball-bearing mounted fan with overheating protection has a low sound level and offers reliable operation. The front panel is hinged, which makes it easy to open for inspecting the coil and fan.

The CAW is available in two models: CAW-a and CAW-s.

Capacity

Pages 8 and 9 give examples of capacities for each size. You can also carry out your own calculations by using our web-based VEAB Select calculation program. (www.veab.com) or get in touch with our sales staff for assistance.

Installation

Can be installed directly on the ceiling or suspended from hangers.



Control

Built-in control equipment

-a

Fan heater with built-in control equipment for external sensor and setpoint adjustment. Can also be controlled by an external 0...10V control signal. See pages 4 and 5.

External control equipment

-s

Fan heater for external control equipment. Has two fan-speeds. See pages 6 and 7.

Approvals

The fan heaters are manufactured in accordance with:
 LVD Directive: EN 60355-1, EN 60335-2-30 and EN 50366
 EMC Directive: EN 61000-6-2 and EN 61000-6-3
 EMF Directive: EN 50366



Overview of range with dimensioned drawing

Type		CAW 11	CAW 21	CAW 41
Power supply		230V~	230V~	230V~
Current, max.	A	0.4	0.6	1.0
Air flow rate (low/high speed)	m ³ /h	700 / 1100	1300 / 2000	2500 / 3900
Sound level ¹⁾ (low/high speed)	dB(A)	37 / 53	44 / 57	48 / 60
Vertical throw ²⁾ (low/high speed)	m	2.2 / 4	2.7 / 4.5	4.5 / 7.5
Vertical throw ²⁾ with CAWE (low/high speed)	m	4 / 7	5 / 8	7 / 12
Connecting pipes	mm dia.	22	22	28
Max. operating water temp., CAW-a	°C	80°C	80°C	80°C
Max. operating water temp., CAW-s	°C	80°C	80°C	80°C
Max. operating pressure (water)	bar	10	10	10
Ambient temperature	°C	3-30°C	3-30°C	3-30°C
Degree of protection		IPX4 ³⁾	IPX4 ³⁾	IPX4 ³⁾
Weight	kg	19	26	41

¹⁾ Measured at 5 metres from the fan outlet.

²⁾ The figures are based on: From the ceiling down to the point at which the air velocity is 0,2 m/s, the room temperature is 18°C and the outlet temperature is 40°C.

³⁾ The -a model is delivered as standard with IP20 valve actuator. Can be changed to IP54 valve actuator to special order.

Dimensions	A mm	B mm	C mm	D mm	E mm	F mm	G mm	H mm	K mm	L mm dia.
CAW 11	535	640	280	670	705	125	195	330	135	305
CAW 21	675	760	420	790	825	115	195	355	160	355
CAW 41	735	1070	480	1100	1135	110	300	415	115	430

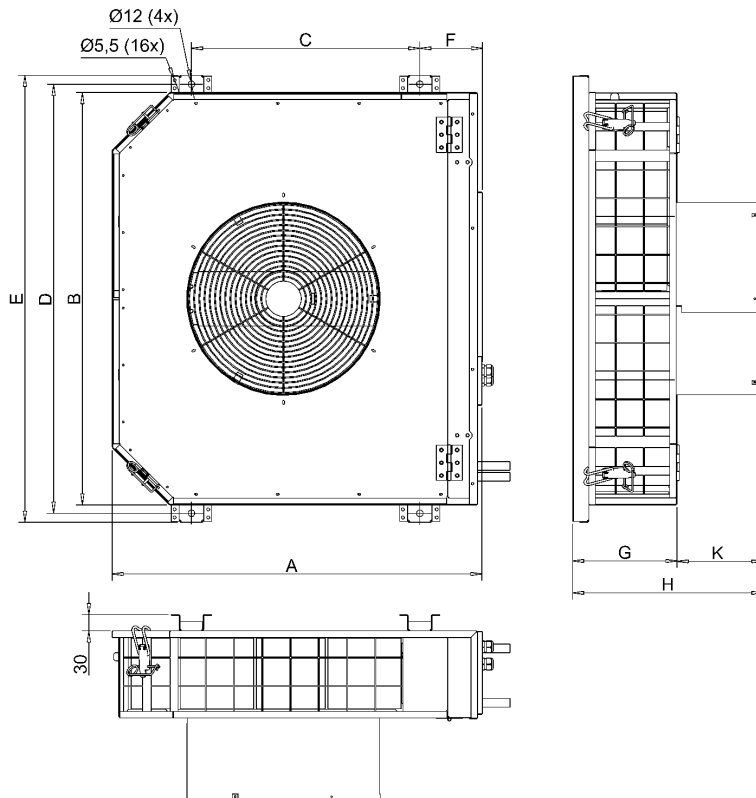

CAW-a

Fan heater for hot water with built-in control equipment for fan and water control

The CAW-a with built-in control equipment gives a simple installation due to fewer cable runs, etc. This, in turn, lowers the installation cost and reduces the risk of incorrect connections. The control equipment is suitable for an external temperature sensor and setpoint adjuster or external 0...10V control signal.

Model –a

The CAW-a has built-in control equipment with electronic thermostat that starts/stops the fan and opens/shuts off the water flow.

The thermostat controls automatically in three steps:

Step 1 – Fan runs only at low speed, without hot water. This function puts to use of the warm air stored under the ceiling, which results in efficient energy utilization and saves money.

Step 2 – The fan runs at low speed and the hot water valve opens.

Step 3 - The fan runs at high speed and the hot water valve opens.

Control

The CAW-a must be supplemented with an external room sensor and setpoint adjuster. See the next page for examples. The CAW-a can also be controlled by an external 0...10V signal.

A CAW-a with sensor connected can carry out slave control of an unlimited number of CAW-a units and/or our wall-mounted type AW-a fan heaters. The slave-controlled units then need no sensors and receive their control signals from the CAW-a with sensor. See next page for sensors.

Accessories

See next page for sensors suitable for the CAW-a.



Installation







The CAW-a is mounted directly on the ceiling or on hangers.

Project design/ordering

Descriptive text - CAW-a

Ceiling-mounted fan heater for hot water, VEAB type CAW-a, with casing of galvanized sheet steel, painted white. Water coils with copper tubes and aluminium fins. The hinged front panel makes the coil and fan easily accessible for inspection and cleaning. Built-in control equipment for fan and water control. Setpoint adjustment is carried out externally. Accessories such as room sensor, setpoint adjuster, filter and extension duct must be ordered separately.

Accessories

	Product	Range	Degree of protection
	Room sensor TG-R430 With setpoint adjustment.	Range 0-30°C	IP30
	Room sensor TG-R530 Supplemented with TG-R430 for setpoint adjustment.	Range 0-30°C	IP30
	Room sensor TG-R630. Supplemented with TG-R430 for setpoint adjustment.	Range 0-30°C	IP54
	Extension duct CAWE The duct is used for greater ceiling heights in order to increase the throw. Length: 350 mm.		
	Filter CAWF Filter for installation in the CAW		
	Air deflector CAWL Aluminium blades. Used for directing the air sideways.		

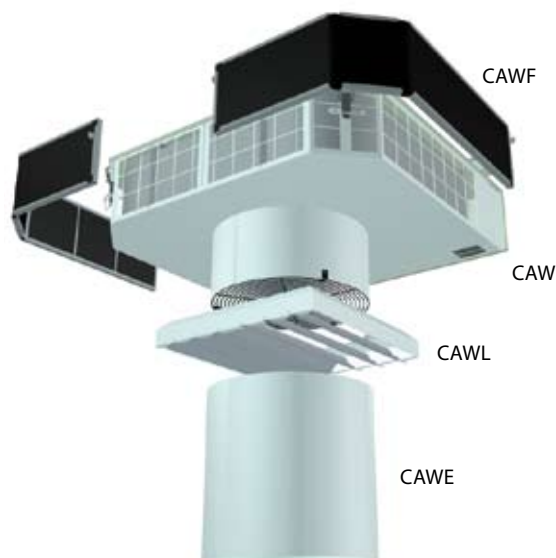

CAW-s

Fan heater for hot water for external control equipment

The CAW-s for external control equipment is the alternative if you require a simple fan heater, but without compromising on quality.

Model –s

The CAW-s for external control equipment has two fan speeds. The speed can be selected on installation or by external type AWD selector switch.

Control

The CAW-s is supplemented with external room thermostat, speed selector switch, and also actuator and valve. See next page for examples.

Accessories

See the next page for accessories suitable for the CAW-s.

Installation

The CAW-s is mounted directly on the ceiling or on hangers.



Project design/ordering

Descriptive text - CAW-s

Ceiling-mounted fan heater for hot water, VEAB type CAW-s, with casing of galvanized sheet steel, painted white. Water coils with copper tubes and aluminium fins. Fan motor with two speeds. The hinged front panel makes the coil and fan easily accessible for inspection and cleaning. Accessories such as thermostat, speed selector switch, actuator and valve, and also extension duct must be ordered separately.

Accessories

	Product	Range	Degree of protection
	Actuator and valve AWTV, IP20 Used together with thermostat TI-N or SR 121/1.	Max 100°C, 10 bar. CAW 11-21: 4,6 Kvs CAW 41: 8,4 Kvs	IP20
	Actuator and valve AWTV, IP54 Used together with thermostat TI-N or SR 121/1.	Max. 100°C, 10 bar CAW 11-21: 5.0 Kvs CAW 41: 8.0 Kvs	IP54
	Speed selector switch CAWC 11-41 Can control up to four CAW-s units. 0 = shut off 1 = low speed 2 = high speed		IP65
	Thermostat SR121/1 Can control four CAW-s.	Range 0-40°C	IP54
	Room thermostat TI-N. Can control up to three CAW-s units. Max. load 10 A (3 A) 250V AC.	Range 5-30°C	IP30
	Extension duct CAWE CAWE is used for greater ceiling heights in order to increase the throw. Length: 350 mm.		
	Filter CAWF Panel filter for installation in the CAW.		
	Air deflector CAWL Aluminium blades. Used for directing the air sideways.		

Capacity of CAW 11

Water temp.		in/out 80°C/60°C				in/out 60°C/40°C				in/out 55°C/45°C			
Air flow rate	Air in	Air out	Output	Flow of water	Pressure drop, water	Air out	Output	Flow of water	Pressure drop, water	Air out	Output	Flow of water	Pressure drop, water
m ³ /h	°C	°C	kW	l/s	kPa	°C	kW	l/s	kPa	°C	kW	l/s	kPa
700	+10	46.0	8.7	0.1	6.2	32.5	5.4	0.06	2.8	34.1	5.8	0.14	11.2
1100	+10	41.7	12	0.15	11.2	29.7	7.5	0.09	4.9	31.4	8.1	0.2	20.5
700	+15	47.9	7.8	0.09	5.1	34.3	4.6	0.06	2.1	36.1	5.0	0.12	8.4
1100	+15	44	10.8	0.13	9.3	40	6.4	0.08	3.8	33.6	6.9	0.17	15.4
700	+20	49.9	6.9	0.09	4.1	36.4	3.8	0.05	1.49	37.9	4.2	0.1	6.1
1100	+20	46.3	9.6	0.11	7.5	34.3	5.3	0.06	2.7	35.9	5.8	0.14	11.1

Capacity of CAW 21

Water temp.		in/out 80°C/60°C				in/out 60°C/40°C				in/out 55°C/45°C			
Air flow rate	Air in	Air out	Output	Flow of water	Pressure drop, water	Air out	Output	Flow of water	Pressure drop, water	Air out	Output	Flow of water	Pressure drop, water
m ³ /h	°C	°C	kW	l/s	kPa	°C	kW	l/s	kPa	°C	kW	l/s	kPa
1300	+10	36.8	12	0.15	4.9	26.8	7.5	0.09	2.2	28.1	8.1	0.2	8.9
2000	+10	33.4	16	0.2	8.4	24.8	10.2	0.12	3.8	25.9	10.9	0.26	15.4
1300	+15	39.5	10.8	0.13	4.0	29.6	6.4	0.08	1.7	30.8	6.9	0.17	6.77
2000	+15	36.5	14.5	0.18	6.9	28.9	8.7	0.11	2.9	28.8	9.3	0.23	11.59
1300	+20	42.2	9.6	0.12	3.3	32.3	5.3	0.06	1.2	33.4	5.8	0.14	4.9
2000	+20	39.4	12.9	0.16	5.6	30.8	7.2	0.09	2.0	31.7	7.8	0.19	8.3

Capacity of CAW 41

Water temp.		in/out 80°C/60°C				in/out 60°C/40°C				in/out 55°C/45°C			
Air flow rate	Air in	Air out	Output	Flow of water	Pressure drop, water	Air out	Output	Flow of water	Pressure drop, water	Air out	Output	Flow of water	Pressure drop, water
m ³ /h	°C	°C	kW	l/s	kPa	°C	kW	l/s	kPa	°C	kW	l/s	kPa
2500	+10	47.2	32	0.39	7.8	33.1	19.9	0.24	3.4	35	21.5	0.52	14.1
3900	+10	42.8	44	0.53	14.0	30.2	27.1	0.33	5.9	32.1	29.7	0.71	25.6
2500	+15	49.1	28.9	0.35	6.5	34.8	16.8	0.20	2.5	36.8	18.4	0.45	10.6
3900	+15	45.0	39.6	0.48	11.5	32.6	23.2	0.28	4.5	34.3	25.3	0.62	19.1
2500	+20	50.9	25.7	0.31	5.2	36.8	14.0	0.17	1.8	38.6	15.4	0.37	7.6
3900	+20	47.1	35.2	0.43	9.3	34.9	19.3	0.23	3.2	36.5	21.2	0.51	13.7

